



CIRCONTROL
Mobility & eMobility

Wallbox eNext Series

Installation Manual



Wallbox eNext Series Installation Manual

COPYRIGHT INFORMATION

This document is copyrighted, 2018 by Circontrol, S.A. All rights are reserved. Circontrol, S.A. reserves the right to make improvements to the products described in this manual at any time without notice.

No part of this manual can be reproduced, copied, translated or transmitted in any form or by any means without the prior written permission of the original manufacturer. Information provided in this manual is intended to be accurate and reliable. However, the original manufacturer assumes no responsibility for its use, or for any infringements upon the rights of third parties that may result from its use.

All other product names or trademarks are properties of their respective owners.

Here's your guide to install eNext.

1 — So, hello!	02	5 — Installation	10
2 — Before the installation	04	6 — Technical Data	18
3 — Overview	06	7 — Need Help?	20
4 — Dimensions	08		

1

PRE-SERIES

So, hello!

This manual provides commissioning information about Wallbox eNext, which has been designed and tested to allow electric vehicle charging, specified in IEC 61851.

This document has different sections such as step-by-step installation procedure and technical data.

THE FOLLOWING SYMBOLS ARE USED FOR IMPORTANT SAFETY INFORMATION IN THIS DOCUMENT



ELECTRIC RISK

Take precautions to make the electrical connection inside the unit.

Unit must be disconnected from any power source during commissioning.



ATTENTION!

Indicates that the damage to property can occur if appropriate precautions are not taken

- Complies with IEC 61851, Electric vehicle conductive charging system (IEC 61851-1 and IEC 61851-22).
- Complies with IEC 62196, Plugs, socket-outlets, vehicle couplers and vehicle inlets (IEC and IEC 62196-2).
- Standards: 2014/35/UE, LVD;2014/30/UE, EMC.
- RFID complies with ISO 14443A/B

2

IMPORTANT SAFETY INSTRUCTIONS



Read carefully all the instructions before starting in order to ensure proper installation of the charge point.

The charge point is designed for installation in indoor and outdoor areas. For each of the different conditions of installation, the unit must be installed safely and ensure adequate protection.

- Charge point must not be installed in areas where there is potential risk of explosions.
- Do not install the charge point where falling objects may damage the equipment.
- The surface where the charge point is placed must withstand the mechanical forces.
- Do not use this unit for anything other than electric vehicle charging modes are expected in IEC 61851.
- Do not modify this unit. If modified, CIRCONTROL will reject all responsibility and the warranty will be void.
- Comply strictly with electrical safety regulations according to your country.
- Do not make repairs or manipulations with the unit energised.
- Only trained and qualified personnel should have access to low-voltage electrical parts inside the unit.
- Check the installation annually by qualified technician.
- Remove from service any item that has a fault that could be dangerous for users (broken plugs, caps that don't close...).
- Use only Circontrol supplied spare parts.
- Do not use this product if the enclosure or the EV connector is broken, cracked, open, or shows any other indication of damage.

Refer to TECHNICAL DATA section for more information about environmental installation conditions.

Before the installation

ELECTRICAL WIRING CONSIDERATIONS



Take into consideration this section before start wiring connections of the charge point.

1 – ELECTRICAL PROTECTIONS

Charge point may not include elements of electrical protection.

If this equipment has internal electrical protections, are installed in each socket-outlet for the protection of the user against an electrical failure, according to the international standard IEC 61851-1:2017.

In order to guarantee the total protection of the users and the installation (power supply line included) in front of any electrical hazard, it is mandatory to install a main circuit breaker (MCB) and a residual current device (RCD) upstream of the charger.

These electrical protections and the rest of the installation have to be aligned with the local and national rules. The selectivity of the protections has to be guaranteed at all times.

2 – POWER SUPPLY LINE DIMENSIONING

The dimensioning of the input power supply line of the charge point must be checked by a qualified electrician. Note that various factors such as cable length between distribution board and charge point, maximum output current of the charge point may have influence of the selected cable.

In such cases, increasing the cable cross-section it is required to adapt the temperature resistance of the power supply line.

3 – MAXIMUM OUTPUT CURRENT

Please refer to the TECHNICAL DATA section to consult the default factory settings from maximum output current of the charge point.

If the power supply is less than maximum output current and adjustment to a lower nominal current needs to be performed, please refer to the INSTRUCTION MANUAL.

Depending of the model this value may vary.

3

What's included:

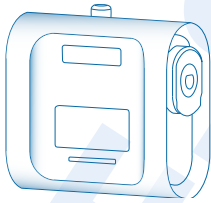
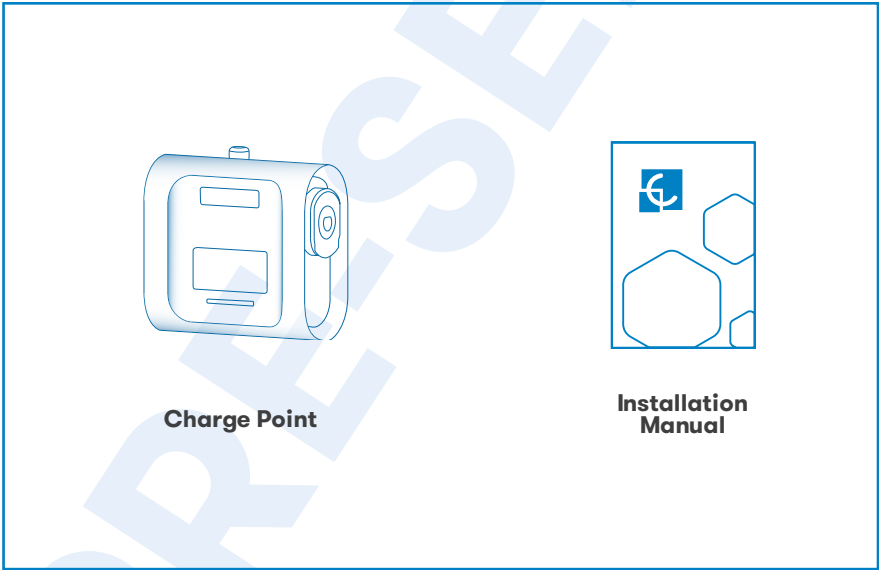

Charge Point



Installation Manual

Overview

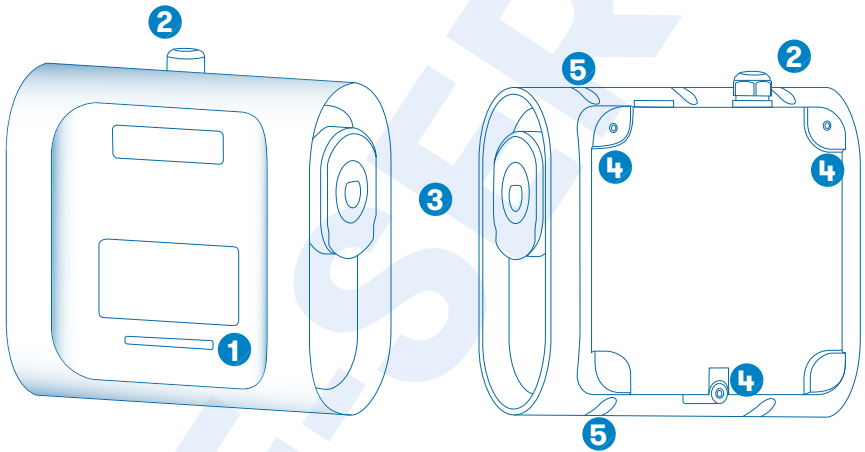

1 – LED beacon

2 – Cable glands

3 – Plugs*

4 – Wall support holes

5 – Closing box holes

(*) Plugs may vary depending on the model

4

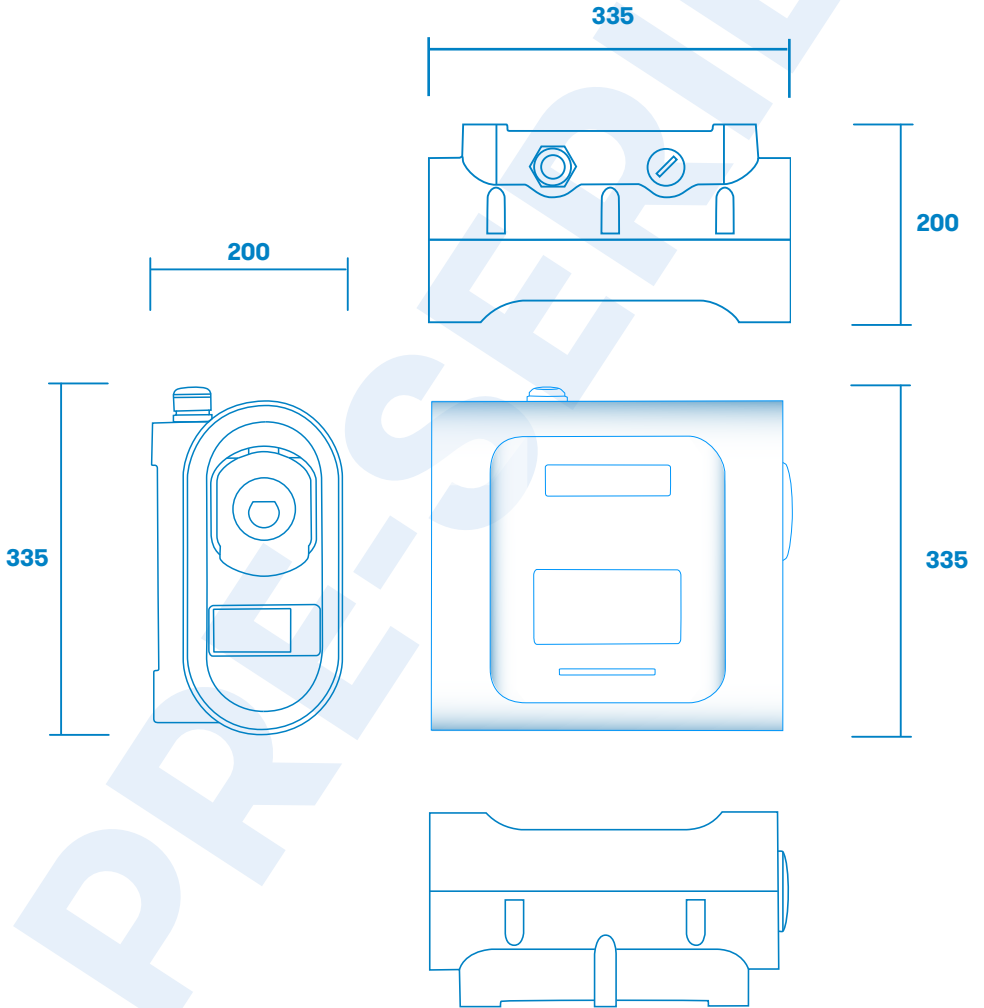

Measures in mm

Dimensions

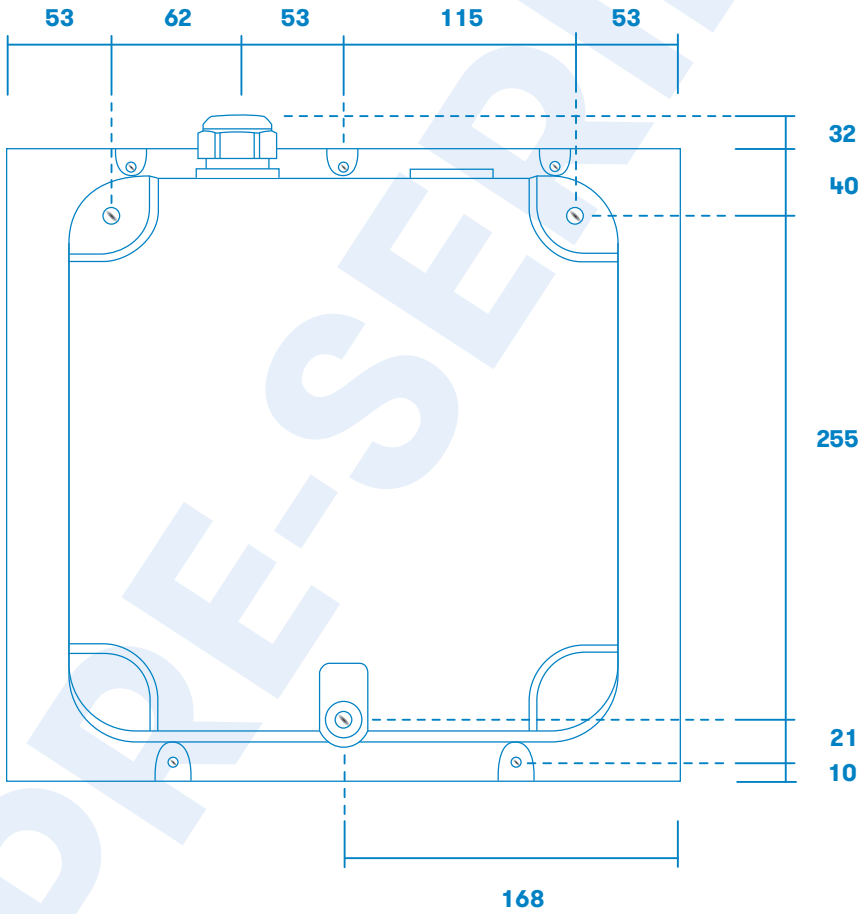

5

Material:



- Screws, sealing washers and plastic anchors are not included.
- The installation kit has been tested on a concrete wall. For the unit to be securely fixed in such conditions, it is recommended to use:

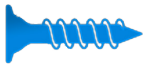

3 x Inox A2 wall screws: DIN 7982 Ø4,8x38 or DIN 7981 Ø4,8x38



3 x plastic anchors: 6x40 or 8x40



3 x sealing washer: DIN 7711 Ø14

- If the installation surface has different properties, the screws and plastic anchors must be defined by a qualified installer.

Tools:



Screw driver



Driller

Tap drill 6/8M



Allen wrench

2.5 mm

Installation

A Space requirements

When installing the unit, some space shall be reserved for usability, maintenance and safety reasons.

Please comply accordingly to your country specifications.

The next picture shows the recommended minimum distances:

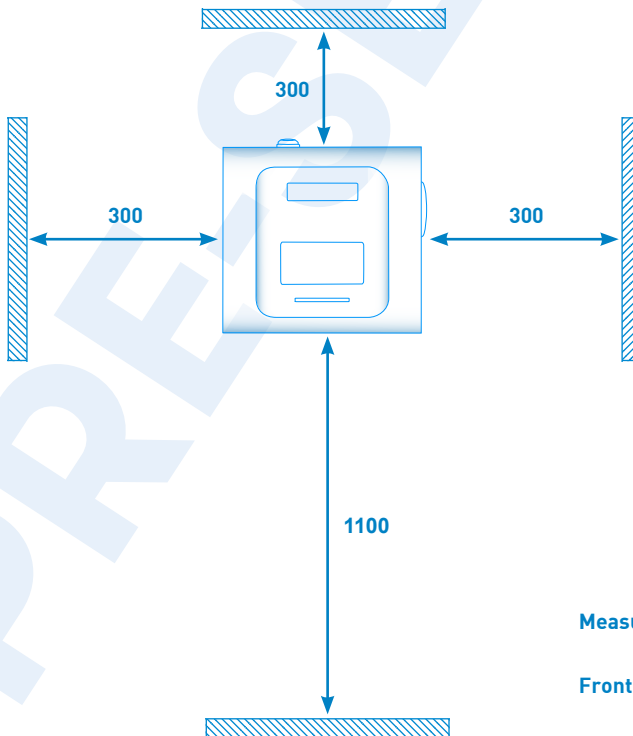

Measures in mm

Front view

B Opening

Open the Wallbox using allen wrench.

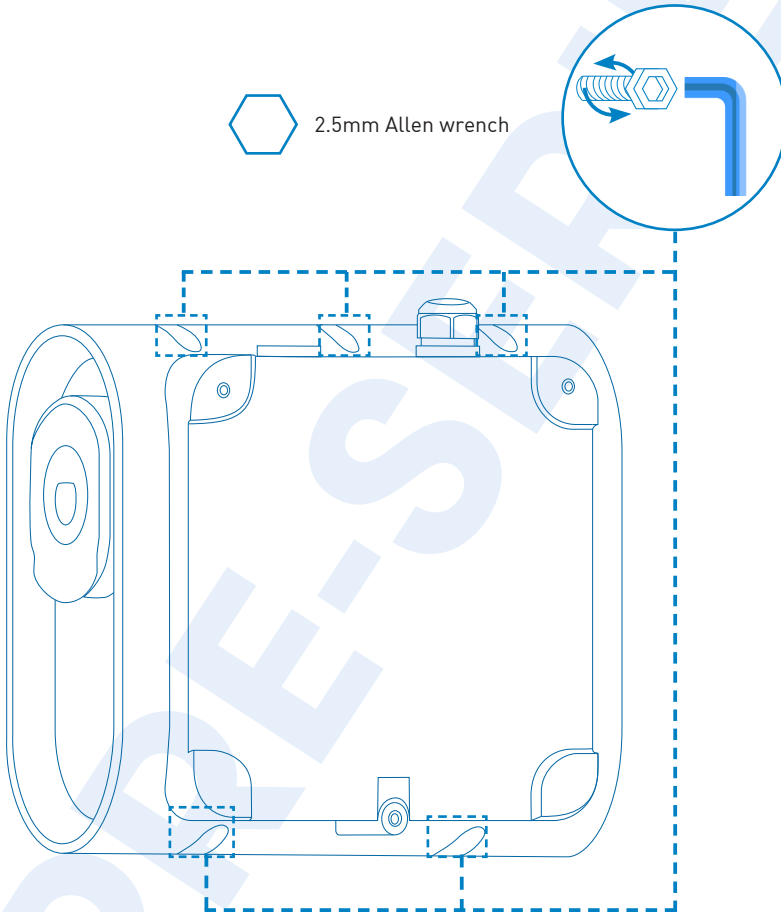

© Positioning

Make the holes.

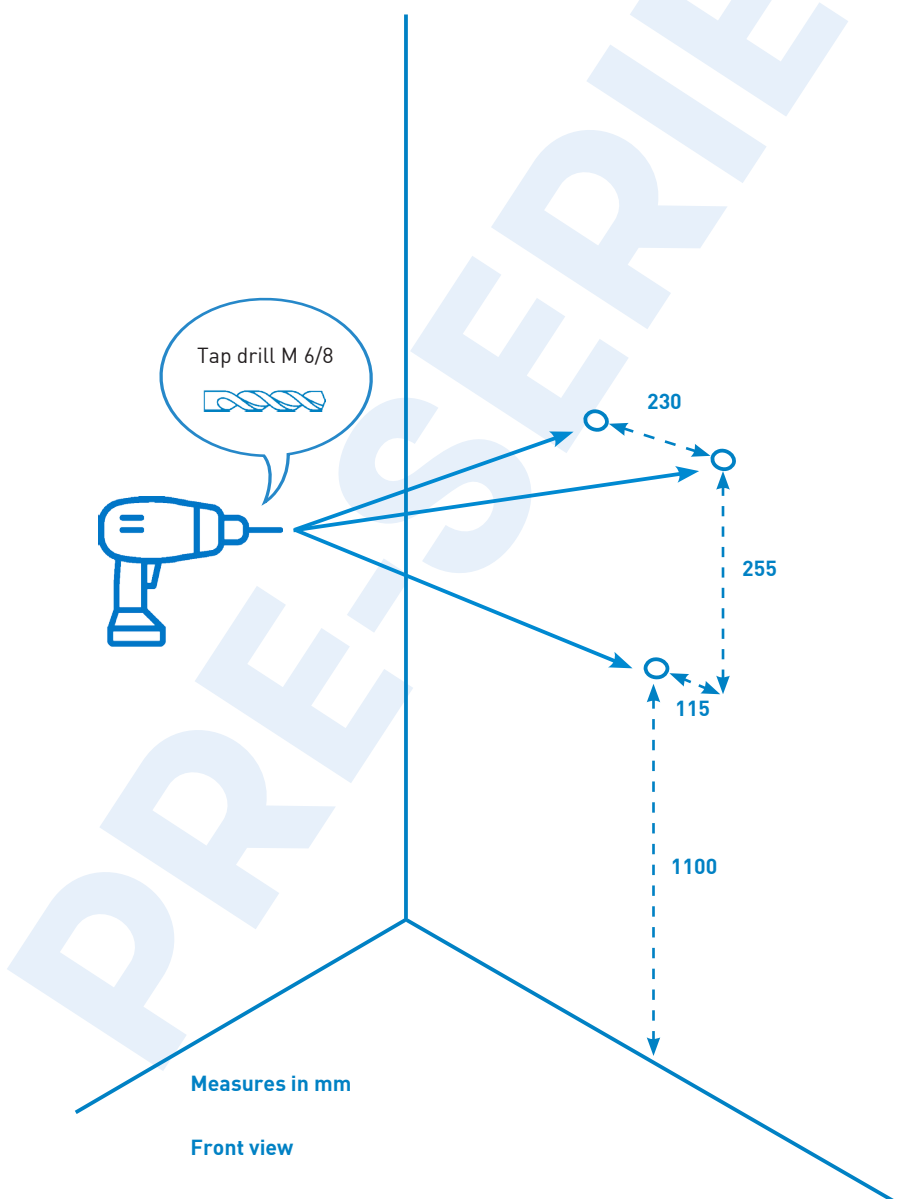

D Positioning

Place de unit on the previously leaky points and fix it by the screws

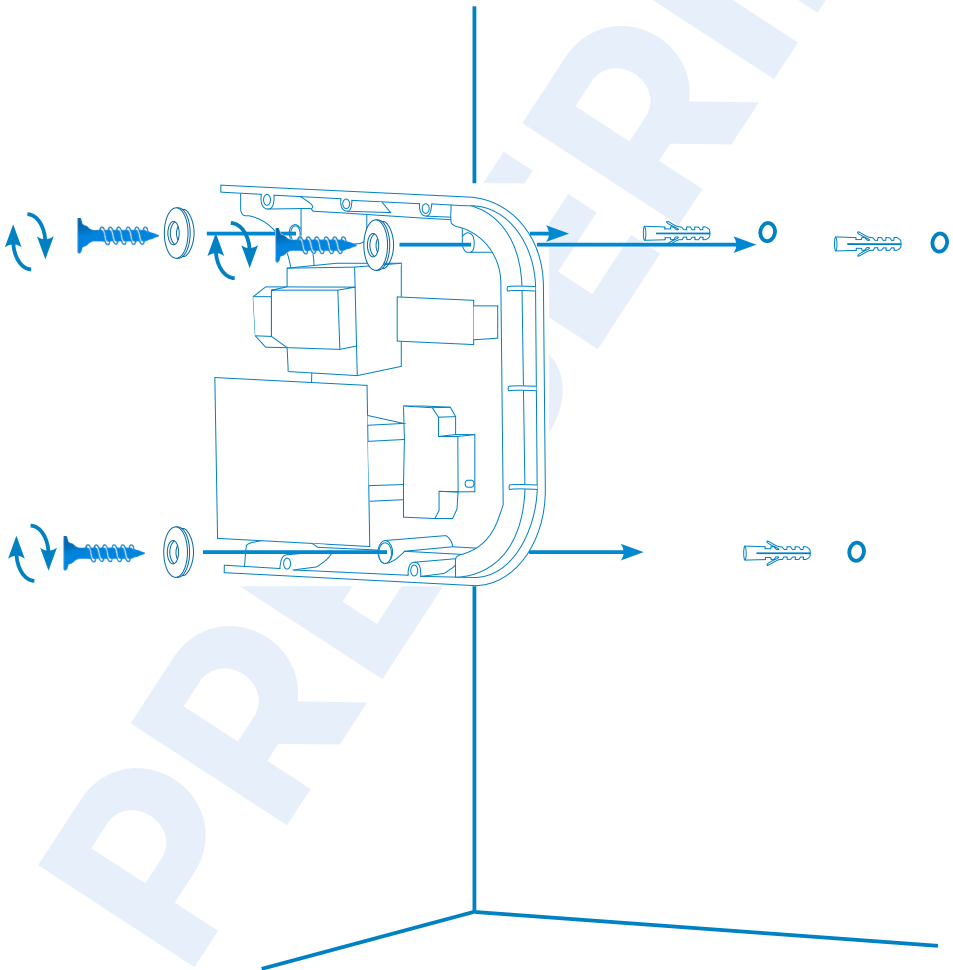

E Wiring

Use provided cable glands in order to maintain the IP protection

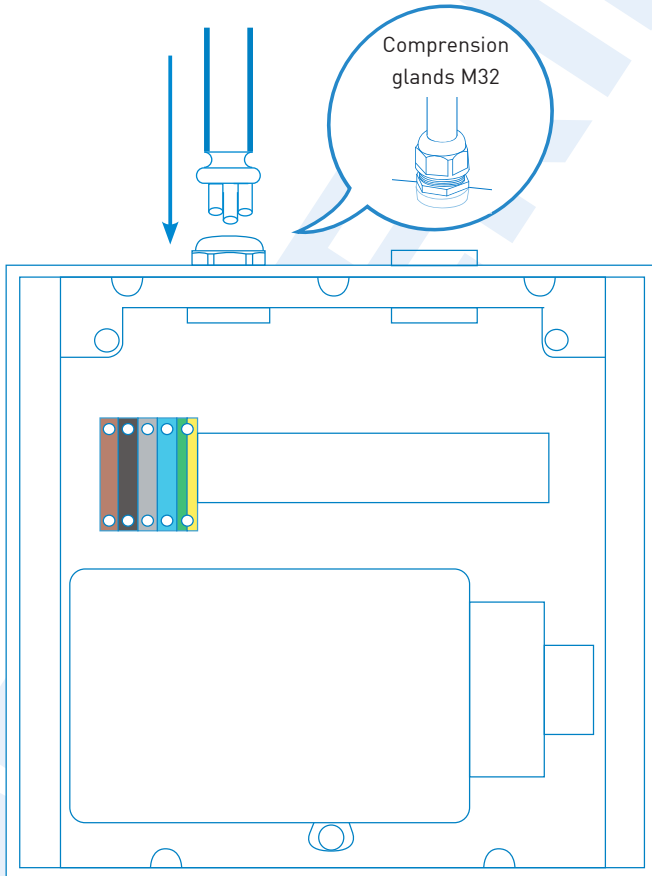

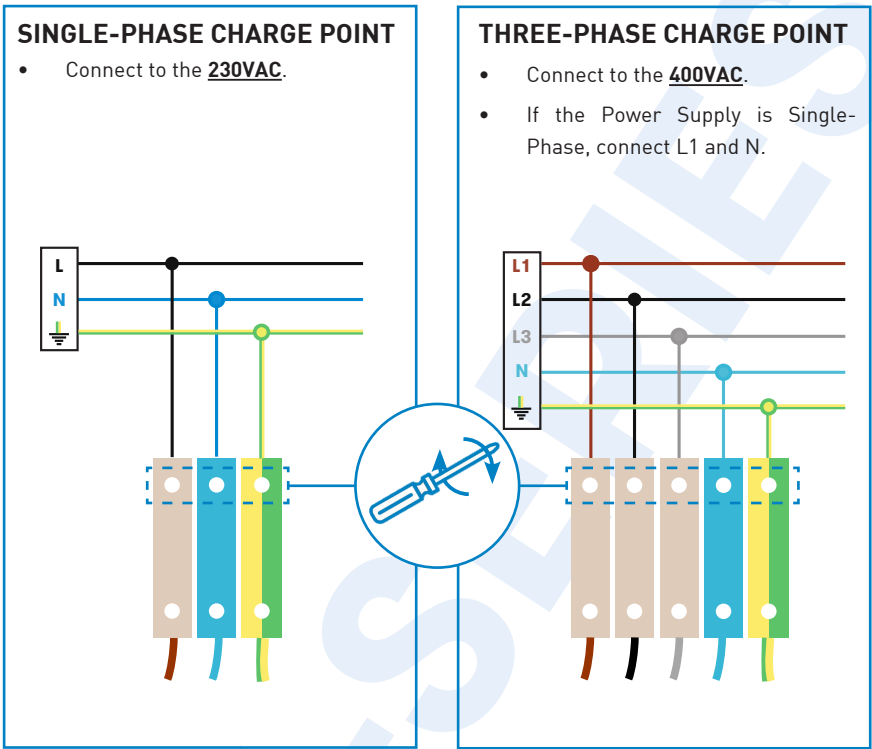

- Terminal block maximum cross-section: 25mm²
- Do not forget to connect the ground cable to the ground terminal
- Type of cable allowed by the terminal block: Aluminium & copper
- Make sure all screws are securely tightened at 4...5 Nm

Note: The proper earthing system must be TT or TN-S. The ground loop impedance measurement for the entire installation must be less than 80 ohms; however, it could be even less if required by national regulations. At least once a year it is recommended to carry out the verification of the installation grounding by qualified personnel when the terrain is drier.

F Verification

1 – POWER INPUT

Before proceeding, make sure voltage is present in the terminal blocks.



For Three-Phase models pay special attention to Neutral Cable.

2 – CAREFUL WITH THE WIRES

Before closing the unit, keep in mind all cables should remain inside.

3 – CHECK THE PLUGS

Plugs should be in good conditions before starting the unit.

4 – ELECTRICAL PROTECTIONS

If the unit includes electrical protections, rearm all of them.

5 – CHECK THE BEACON INDICATORS

All beacon indicators should light properly. Here's the reference:

PLUG STATE	BEACON COLOR
Available	Green
Charging	Blue
Fault	Red

6 – OPERATION

Check no abnormal noise appears while the unit is charging.

7 – PREVENTIVE MAINTENANCE

It is recommended to perform one preventive maintenance per year.

6

GENERAL DATA

Light beacon	Frontal LED bar
Wireless communication	Bluetooth v4.2 + BLE
Connectors (optional)	Shutter Type 2 Socket
	Cable Type 1
	Cable Type 2

MECHANICAL DATA

Enclosure rating	IP54 / IK10
Enclosure material	ABS / PC
Enclosure closure system	Anti-vandalism Allen screws
Net weight	4 kg
Dimensions (W x H x D)	335 x 335 x 200 mm

ENVIRONMENTAL CONDITIONS

Operating temperature	-5°C to +45°C
Operating temperature with Low Temperature Kit (optional)	-30°C to +45°C
Storage temperature	-20°C to +60°C
Operating humidity	5% to 95% Non-condensing

Technical Data

ELECTRICAL DATA	
Power supply	1P+N+PE / 3P+N+PE
Input voltage	230VAC+/-10% / 400VAC+/-10%
Frequency	50Hz / 60Hz
Protections (optional)	MCB (curve C) - includes shunt trip
	Leakage detector (MCB/RCBO with shunt trip is required to open the circuit)
	RCBO: RCD Type A (S) + MCB (S) - includes shunt trip
Overvoltage protection (optional)	Transient surge protector IEC 61643-1 (Class II)



Protections may not be included in the charge point, at this point, protections with the same characteristics, shall be placed upstream. The national regulations must be taken into account.

MODEL*	CONNECTORS*	OUTPUT CURRENT	OUTPUT POWER	MINIMUM CABLE CROSS-SECTION**
S	Type 2 Cable	32A	7,4kW	10mm ²
T	Type 2 Socket	32A	22kW	10mm ²

[*] Please consult the availability to your local supplier

[**] Minimum cable section recommended for the maximum AC input current, the final section must be calculated by a qualified technician taking into account the specific conditions of the installation.

7

PRE-SERIES

Need help?

In case of any query or need further information, please contact our **Post-Sales Department**



ps-support@circontrol.com



circontrol.com



[+34] 937 362 940



[+34] 937 362 941



CIRCONTROL
Mobility & eMobility

**CIRCONTROL
WALLBOX ENEXT
INSTALLATION MANUAL**

A comprehensive guide on
how to install and verify
your Wallbox eNext.

V1.0, November edition 2018